

Hydraulic Clamp Nut

Grease coupling system



Series 020 / 120

Features of series

**Axial connected
grease pump**

**New medium is applied
with each clamping operation**



The pressure is based by the connection with the grease pump.
The internal medium will flow into the circular groove and raise the ring piston.
Pressure rate is shown precisely at the pressure gauge.
For to relieve you have to open the release-screw and then turn the nut to the opposite direction.
During the release operation, medium will drop out of the release-screw.
That volume will be reloaded at the next clamping operation.

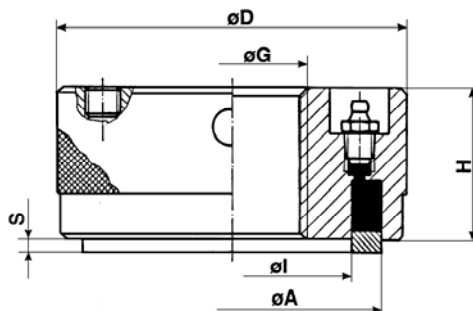

Clamping range 4 mm

Thread $\varnothing G_{max.}$	Ring piston		Outer Diameter $\varnothing D$	Height H	Clamping Force in kN Pump with max.working pressure		Part No Clamping range S 4 mm
	$\varnothing A$	$\varnothing I$			400 bar	700 bar	
36	66	46	80	50	70	120	020.04.036
52	82	62	96	50	90	160	020.04.052
68	100	80	116	50	110	195	020.04.068
100	130	112	150	50	135	240	120.04.100
125	160	138	180	50	205	360	120.04.125
140	175	155	195	50	205	360	120.04.140
165	200	180	220	50	240	415	120.04.165
185	222	202	242	50	265	465	120.04.185
200	240	215	260	50	355	625	120.04.200
225	272	240	292	50	510	900	120.04.225

Against corrosion our hydraulic clamp nuts are protected with a brown finish.
The standard sealing systems are suitable for temperatures up to 80°.
The ring piston is locked against drop out.

Special design of hydraulic clamp nuts on request



AVEMAR CZECH s.r.o. | speciální armatury pro měření a regulaci
Branch office | Lihovarská 1199/10 | 716 03 Ostrava - Radvanice | Česká republika
Tel.: +420 596 232 996 (7) | Fax: +420 596 232 998 | www.avemar.cz | avemar@avemar.cz